



Flange Drilling

BS 4504 PN16,
other standard on request.

Coating

High solid epoxy coating
standard, other coating on
request.

Properties

- Increases the life span of water meters.
- Improves the reticulation for bulk meter system.
- Reduces the maintenance and cost of water meters.
- Dirt and debris accumulated can be flushed out through drain plug.

SPECIFICATIONS

| No | Part | Material Description |
|----|--------|--------------------------------------|
| 1 | Body | Ductile Iron, BS EN 1563 Grade 500/7 |
| 2 | Gasket | EPDM BS 2494 Type W / MS 672: 99 |
| 3 | Bolt | Stainless Steel 304 |
| 4 | Screen | Stainless Steel 304 |
| 5 | Cover | Ductile Iron, BS EN 1563 Grade 500/7 |
| 6 | Bolt | Stainless Steel 304 |

DIMENSIONS

| DN | H | L | D | D1 | D2 | B | b | n - Ø |
|-----|-----|-----|-----|-----|-----|----|----|-----------|
| 80 | 260 | 240 | 200 | 160 | 132 | 19 | 9 | 8 - Ø 19 |
| 100 | 280 | 280 | 220 | 180 | 156 | 19 | 10 | 8 - Ø 19 |
| 150 | 380 | 360 | 285 | 240 | 211 | 19 | 12 | 8 - Ø 23 |
| 200 | 440 | 420 | 340 | 295 | 266 | 20 | 14 | 12 - Ø 23 |

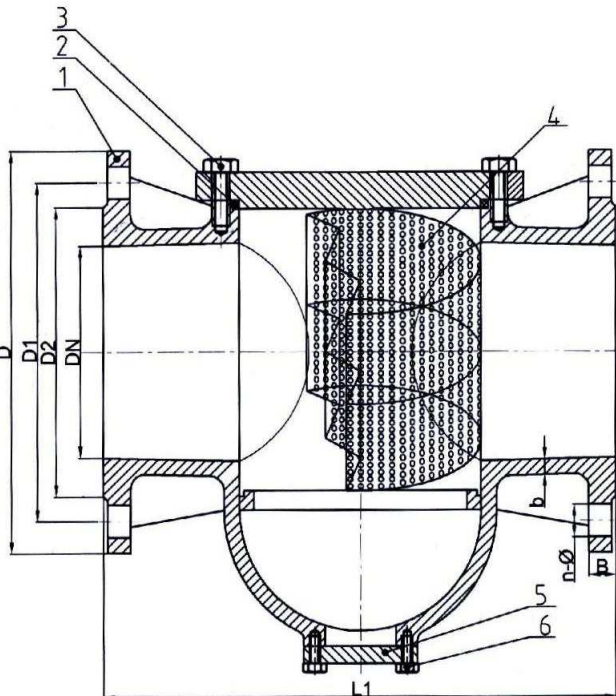

Sales Office :

TEK VALVE (M) SDN. BHD. (Company No : 524990-A)

PT 22432, Lot Asal 6535, Sungai Puloh, Batu 5 1/2,
Jalan Kapar, 42450 Klang, Selangor Darul Ehsan.

Tel : (006) 03-3291 3963

Fax:(006) 03-3290 5126

E-mail: tekvalve@yahoo.com